



FEDERATION INTERNATIONALE DES LUTTES ASSOCIEES
INTERNATIONAL FEDERATION OF ASSOCIATED WRESTLING STYLES

Adresse : Rue du Château 6 / 1804 Corsier-sur-Vevey / Suisse **Téléphone** : (41.21) 312 84 26 **Fax** : (41.21) 323 60 73 **E-mail** : fila@fila-wrestling.com **Internet** : www.fila-wrestling.com

INTERNATIONAL WRESTLING RULES

GRECO-ROMAN WRESTLING FREESTYLE WRESTLING FEMALE WRESTLING

Version June 2013



FEDERATION INTERNATIONALE DES LUTTES ASSOCIEES
INTERNATIONAL FEDERATION OF ASSOCIATED WRESTLING STYLES

FOREWORD

Wrestling, like all other sports, obeys Rules that constitute the "Rules of the Game" and define its practice, the aim of which is to "pin" the opponent or to win on points.

Greco-Roman and Freestyle wrestling basically differ as follows:

In Greco-Roman Wrestling, it is strictly forbidden to grasp the opponent below the belt line, or to trip him or to use the legs actively to perform any action.

In Free Style wrestling, however, it is permissible to grasp the legs of the opponent, to trip him and to use the legs actively to perform any action. Female wrestling follows the rules of freestyle, forbidding however the Double Nelsons.

Beach Wrestling, Grappling, Pankration Athlima, Belt Wrestling, and Traditional Wrestling are subject to specific regulations.

Frequently modified and always subject to further modification, the Rules set forth herein must be known and accepted by all wrestlers, coaches, referees and leaders. They call upon those who practise the sport to fight totally and universally, with complete honesty and fair play for the pleasure of the spectators.



FEDERATION INTERNATIONALE DES LUTTES ASSOCIEES
INTERNATIONAL FEDERATION OF ASSOCIATED WRESTLING STYLES

Adresse : Rue du Château 6 / 1804 Corsier-sur-Vevey / Suisse **Téléphone** : (41.21) 312 84 26 **Fax** : (41.21) 323 60 73 **E-mail** : fila@fila-wrestling.com **Internet** : www.fila-wrestling.com

TABLE OF CONTENTS

GENERAL RULES	5
ARTICLE 1 – OBJECT	5
ARTICLE 2 – INTERPRETATION.....	5
ARTICLE 3 – APPLICATION.....	5
CHAPTER 1 – MATERIAL STRUCTURE	5
ARTICLE 4 – THE MAT	5
ARTICLE 5 – COMPETITOR’S DRESS	7
ARTICLE 6 – COMPETITOR’S LICENCE	8
ARTICLE 7 – AGE, WEIGHT AND COMPETITION CATEGORIES	8
CHAPTER 2 – COMPETITIONS AND PROGRAMMES	10
ARTICLE 8 – COMPETITION SYSTEM	10
ARTICLE 9 – COMPETITION PROGRAMME	13
ARTICLE 10 – AWARD CEREMONIES	13
CHAPTER 3 – COMPETITION PROCEDURE	13
ARTICLE 11– WEIGH-IN	13
ARTICLE 12 – DRAWING OF LOTS	14
ARTICLE 13 – STARTING LIST.....	14
ARTICLE 14 – PAIRING.....	14
ARTICLE 15 – ELIMINATION FROM THE COMPETITION	15
CHAPITRE 4 – REFEREEING BODY	15
ARTICLE 16– COMPOSITION.....	15
ARTICLE 17 – GENERAL DUTIES	16
ARTICLE 18 – REFEREE’S DRESS	17
ARTICLE 19 – THE REFEREE	17
ARTICLE 20 – THE JUDGE	18
ARTICLE 21 – THE MAT CHAIRMAN.....	19
ARTICLE 22 – THE JURY OF APPEAL.....	20
ARTICLE 23 – PENALTIES AGAINST THE REFEREEING BODY	20
CHAPTER 5 – THE BOUT	21
ARTICLE 24– DURATION OF THE BOUT.....	21
ARTICLE 25 – CALL TO THE MAT.....	21
ARTICLE 26 – PRESENTATION OF WRESTLERS	21
ARTICLE 27 – START	21
ARTICLE 28 – INTERRUPTING THE BOUT	22
ARTICLE 29 – END OF THE BOUT	22
ARTICLE 30 – INTERRUPTING AND CONTINUING THE BOUT	23
ARTICLE 31 – TYPES OF VICTORIES.....	23
ARTICLE 32 – THE COACH	24
ARTICLE 33 – THE CHALLENGE	24
ARTICLE 34 – TEAM RANKING DURING INDIVIDUAL COMPETITIONS.....	25
ARTICLE 35 – RANKING SYSTEM DURING TEAM COMPETITIONS.....	26
CHAPTER 6 – POINTS FOR ACTIONS AND HOLDS	27
ARTICLE 36 – EVALUATION OF THE IMPORTANCE OF THE ACTION OR HOLD	27
ARTICLE 37 – DANGER POSITION	28



FEDERATION INTERNATIONALE DES LUTTES ASSOCIEES
INTERNATIONAL FEDERATION OF ASSOCIATED WRESTLING STYLES

Adresse : Rue du Château 6 / 1804 Corsier-sur-Vevey / Suisse
Téléphone : (41.21) 312 84 26 Fax : (41.21) 323 60 73 E-mail : fila@fila-wrestling.com Internet : www.fila-wrestling.com

ARTICLE 38 – RECORDING THE POINTS	28
ARTICLE 39 – GRAND AMPLITUDE THROW	28
ARTICLE 40 – VALUE ASSIGNED TO THE ACTIONS AND HOLDS	29
ARTICLE 41 – DECISION AND VOTE.....	30
ARTICLE 42 – DECISION TABLE	31
CHAPITRE 7 – CLASSIFICATION POINTS AWARDED AFTER A BOUT.....	31
ARTICLE 43 – CLASSIFICATION POINTS	31
ARTICLE 44 – THE FALL.....	32
ARTICLE 45 – TECHNICAL SUPERIORITY.....	32
CHAPITRE 8 – NEGATIVE WRESTLING.....	33
ARTICLE 46 – PAR TERRE POSITION DURING THE BOUT	33
ARTICLE 47 – RED ZONE	33
ARTICLE 48 –ENFORCEMENT OF PASSIVITY (FREESTYLE AND GRECO ROMAN)	34
CHAPTER 9 – PROHIBITIONS AND ILLEGAL HOLDS	36
ARTICLE 49 – GENERAL PROHIBITIONS.....	36
ARTICLE 50 – FLEEING A HOLD	36
ARTICLE 51 – FLEEING THE MAT	37
ARTICLE 52 – ILLEGAL HOLDS	38
ARTICLE 53 – SPECIAL PROHIBITIONS.....	39
ARTICLE 54 – CONSEQUENCES AFFECTING THE BOUT	39
CHAPITRE 10 – THE PROTEST	39
ARTICLE 55 – THE PROTEST	39
CHAPITRE 11 – MEDICAL	40
ARTICLE 56 – MEDICAL SERVICE.....	40
ARTICLE 57 – MEDICAL SERVICE INTERVENTIONS	40
ARTICLE 58 – DOPING	41
CHAPTER 12 – APPLICATION OF THE WRESTLING RULES.....	41
APPENDIX	
BASIC VOCABULARY	
SCORESHEET – FREESTYLE AND FEMALE WRESTLING	
SCORESHEET – GRECO-ROMAN	
COMPETITION SHEET	
COUNTRIES’ ABBREVIATIONS	



FEDERATION INTERNATIONALE DES LUTTES ASSOCIEES
INTERNATIONAL FEDERATION OF ASSOCIATED WRESTLING STYLES

GENERAL RULES

Article 1 – Object

Drawn up in compliance with the FILA Constitution, the Financial Regulations, the Disciplinary Regulations, the General Rules governing the organisation of international competitions, and all the specific Regulations, the International Wrestling Rules have as their specific objectives to:

- Define and specify the practical and technical conditions under which bouts are to take place;
- Determine the competition system, methods of victory, defeat, classification, penalty, elimination of competitors, etc;
- Determine the value to be assigned to wrestling actions and holds;
- List situations and prohibitions;
- Determine the technical functions of the officials.

Being subject to modification in light of practical observations as to their application and research into their effectiveness, the international Rules set forth in the following document constitute the framework within which the sport of wrestling is conducted in all its styles.

Article 2 – Interpretation

In the event of disagreement as to the interpretation of the provisions of any article in the following Rules, the Executive Bureau of FILA is solely empowered to determine the exact meaning of the article(s) in question. The French text shall prevail.

Article 3 – Application

Application of these Rules to the Olympic Games, Championships, and to all international competitions under the control of FILA is compulsory.

During international tournaments, a competition procedure that differs from that set out in the Rules may exceptionally be used, provided that permission has been granted by FILA and all participating countries.

CHAPTER 1 – MATERIAL STRUCTURE

Article 4 – The Mat

A new FILA approved mat, with a 9m diameter and surrounded by a 1.50m border of the same thickness is obligatory in the following contests: Olympic Games, Championships and Cups. For all other international competitions, mats must be homologated, but not necessarily new.

For the Olympic Games and World Championships, warm up and training mats must also be new and approved by FILA and be of the same quality as the competition mats.

A red band of 1m wide and forming an integral part of the wrestling area is drawn along the circumference on the inside of the circle of 9m in diameter.

The following terms will be used to designate the various parts of the mat:

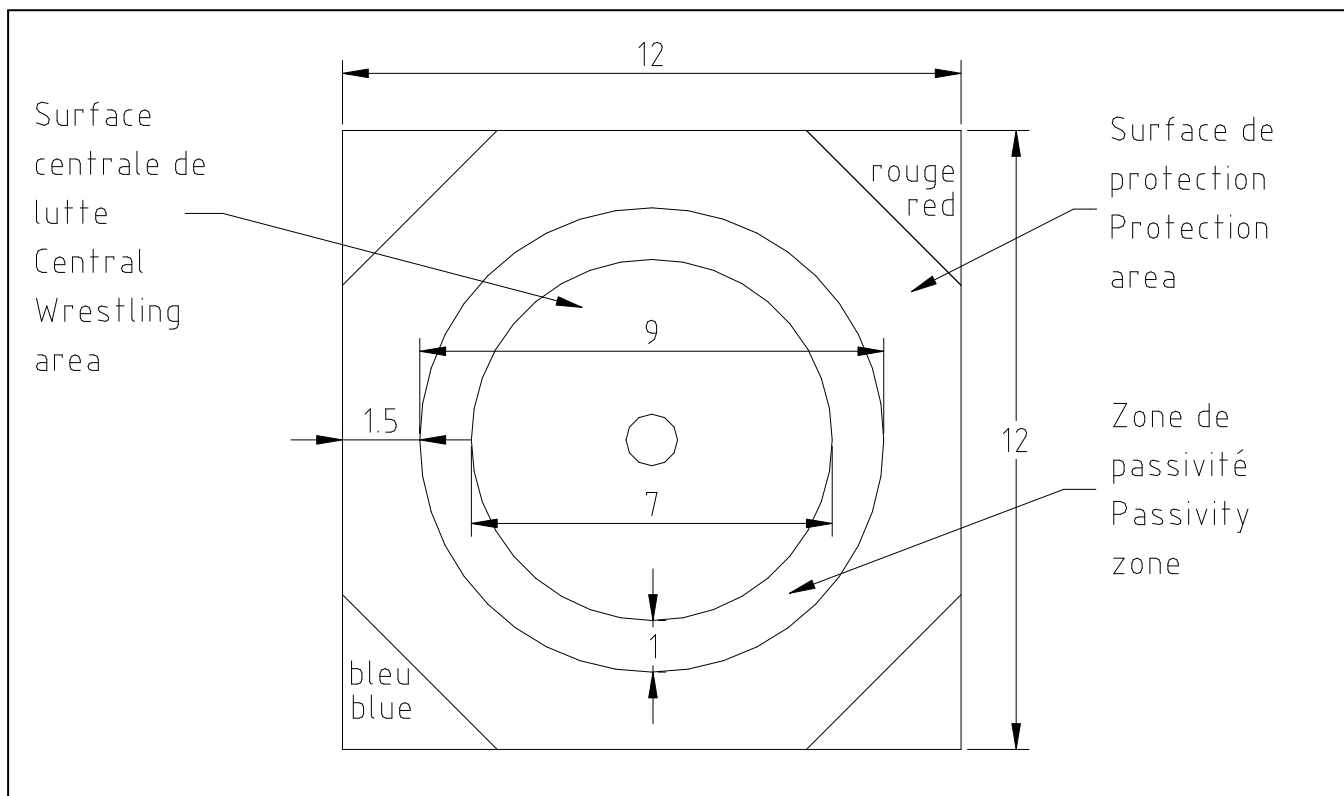

The central circle indicates the middle of the mat (1m of diameter). The inside part of the mat which is inside the red circle is the central surface of wrestling (7m of diameter). The red strip is 1m wide. The protection area is 1m50 wide.

For all Olympic Games, World and Continental Championships, the mat shall be installed on a platform not higher than 1m10 or lower than 0m50. If the mat lays on a podium and that the protection margin (covering and free space around the mat) does not reach 2 meters, the sides of the podium will have to be covered with 45° inclined panels. In all cases, the colour of the protection area will have to be different from the one of the mat. The wooden floor near the mat will have to be covered with a strongly well fixed soft cover.

To prevent contamination, the mat must be cleaned and disinfected before every wrestling session. When mats that have a smooth, uniform and non-abrasive surface are used (canvas included), the same hygienic measures must also be applied.

A circle must be traced in the middle of the mat with an inside diameter of one metre and a surrounding band 10 cm wide. For Greco-Roman wrestling, an 8 cm width line splits the circle in two parts. Two perpendicular lines are traced 40 cm from each other and are called « inside hand line » and « inside knee line ». The colour of the lines just described and that of the line marking off the wrestling area must be red.

The diagonally opposite corners of the mat are marked out in the wrestlers' colours, red and blue.



FEDERATION INTERNATIONALE DES LUTTES ASSOCIEES
INTERNATIONAL FEDERATION OF ASSOCIATED WRESTLING STYLES

The mat should be installed so that it is surrounded by a wide open space in order to ensure that the competition proceeds normally.

Article 5 – Competitor’s Dress

At the beginning of each day, each competitor must be closely shaven or have a beard of several months' growth.

The competition singlet

Contestants must appear on the edge of the mat wearing a FILA approved one-piece singlet of the colour assigned to them (red or blue). It is forbidden to have a mixture of red and blue colours on the singlet. The wrestlers must wear:

- Their country’s emblem on the chest.
- The abbreviation of the country’s name (maximum size 10cm x 10cm) on the back of the singlet and the last name in latin letters (4 to 7 cm) above or in a half circle around the country’s abbreviation.
- The use of light knee pads containing no metal parts is allowed.
- The wrestler must have a cloth handkerchief with him during the whole of the match.

Advertising on clothing

Apart from during the Olympic Games where the IOC Rules apply, competitors can wear one or several sponsors' names. Contestants may also wear their sponsors' name(s) on the back or sleeves of their robes. Lettering and symbols may not be higher than 6 cm to identify the sponsor(s).

Ear protectors

For those wrestlers who wish to wear ear protectors, they must be approved by FILA and must not contain any metal or have hard shells. The referee can oblige a wrestler whose hair is too long to wear ear protectors.

Shoes

Contestants must wear wrestling shoes providing firm support for the ankles. The use of shoes with heels or nailed soles, shoes with buckles or with any metallic part, is prohibited. Shoes may be without laces. Shoes with laces should be wrapped with sticky tape or a system which hides laces so that they do not come undone during the match. Each competitor is responsible for providing the tape himself for the shoes which will be controlled before getting on to the mat.

Bans

At the weigh-in, the referee must check that each competitor satisfies the requirements of this article. The wrestler must be warned at the weigh-in that, if his appearance is not correct, he will not be allowed to enter the competition. If the wrestler enters the mat with a non compliant appearance, officials will allow maximum one minute in order for him to comply. If, after this time, the wrestler is still at fault, he will lose the match by abandon.

It is prohibited to:

- Wear the emblem or abbreviation of another country.
- Wear bandages on wrists, arms or ankles except in the case of injury and on doctor’s orders. These bandages must be covered with elastic straps.
- Apply any greasy or sticky substance to the body



FEDERATION INTERNATIONALE DES LUTTES ASSOCIEES
INTERNATIONAL FEDERATION OF ASSOCIATED WRESTLING STYLES

- Arrive at the mat perspiring for the beginning of the match and for the beginning of each period.
- Wear any object that might cause injury to the opponent, such as rings, bracelets, prosthesis, etc.
- Wear under-wired bras for female wrestlers

Article 6 – Competitor’s Licence

Any male or female cadet, junior and senior wrestler who competes in the Olympic Games, World Championships, World Cups, Continental Championships, Cups and Games, Regional Games and the World and Continental League, international tournaments registered in the FILA calendar must hold an international competitor’s licence, as defined by special Regulations.

Any veteran wrestler who competes in the World Championships and other international competitions must also hold an international competitor’s licence.

This licence is also used as insurance for medical and hospital expenses in case of an accident taking place during the international competition the wrestler is participating in.

The competitor must, at the time of the weigh-in, present his licence and passport to the official delegate who, in turn shall submit it for verification to the FILA representative. The latter shall return it on the same day to the team manager of the said competitor. For competitions in which no accreditation is organised, these documents must be presented at weigh-in.

The licence is only valid for the current year and must be renewed each year.

Article 7 – Age, Weight and Competition Categories

Age categories

The age categories are as follows:

Schoolboys	14-15 years (from 13 with medical and parental certificate)
Cadets	16-17 years (from 15 with medical and parental certificate)
Juniors	18-20 years (from 17 with medical and parental certificate)
Seniors	20 years and older
Veterans	older than 35 years

Wrestlers in the junior age category are allowed to participate in the competitions for seniors. However, wrestlers aged 18 in the year concerned must provide a medical certificate and parental authorisation. Wrestlers aged 17 in the year in question may not participate in senior competitions.

Age will be verified at all Championships and competitions during the accreditation.

An honour certificate for each participant will be issued by the President of the National Federation attesting to the age of the wrestler; this certificate must be drawn up in accordance with the model supplied by FILA, on the National Federation’s letterhead.

A wrestler may participate in a competition only under the nationality appearing on his passport. If, at any time, it is determined by FILA that the statement was false and that fraud occurred, the disciplinary measures provided for to this end will be immediately applied against the Federation, the wrestler and the person whose signature appears on the fraudulent certificate.



FEDERATION INTERNATIONALE DES LUTTES ASSOCIEES
INTERNATIONAL FEDERATION OF ASSOCIATED WRESTLING STYLES

Adresse : Rue du Château 6 / 1804 Corsier-sur-Vevey / Suisse
Téléphone : (41.21) 312 84 26 Fax : (41.21) 323 60 73 E-mail : fila@fila-wrestling.com Internet : www.fila-wrestling.com

Wrestlers who change their nationality and wish to participate in an international competition with their new country must wait two (2) years after their last competition registered in the FILA calendar. Wrestlers can change their nationality only once. Afterwards, they cannot compete for their old country anymore.

Each wrestler who participates in a competition automatically agrees to FILA to use his filmed or photographed image for the promotion of the competition or of competitions to come. If a wrestler refuses to agree to these conditions, he will have to make this clear at the entry stage and, may therefore be excluded from the competition.

Weight categories

The weight categories for freestyle and Greco-Roman wrestling are as follows:

SCHOOLBOYS	CADETS	JUNIORS	SENIORS
1. 29-32 kg	1. 39-42 kg	1. 46-50 kg	1. 50-55 kg
2. 35 kg	2. 46 kg	2. 55 kg	2. 60 kg
3. 38 kg	3. 50 kg	3. 60 kg	3. 66 kg
4. 42 kg	4. 54 kg	4. 66 kg	4. 74 kg
5. 47 kg	5. 58 kg	5. 74 kg	5. 84 kg
6. 53 kg	6. 63 kg	6. 84 kg	6. 96 kg
7. 59 kg	7. 69 kg	7. 96 kg	7. 96-120 kg
8. 66 kg	8. 76 kg	8. 96-120 kg	
9. 73 kg	9. 85 kg		
10. 73-85 kg	10. 85-100 kg		

The weight categories for female wrestling are as follows:

SCHOOLGIRLS	CADETS	JUNIORS	SENIORS
1. 28-30kg	1. 36-38kg	1. 40-44kg	1. 44-48kg
2. 32kg	2. 40kg	2. 48kg	2. 51kg
3. 34kg	3. 43kg	3. 51kg	3. 55kg
4. 37kg	4. 46kg	4. 55kg	4. 59kg
5. 40kg	5. 49kg	5. 59kg	5. 63kg
6. 44kg	6. 52kg	6. 63kg	6. 67kg
7. 48kg	7. 56kg	7. 67kg	7. 67-72kg
8. 52kg	8. 60kg	8. 67-72kg	
9. 57kg	9. 65kg		
10. 57-62kg	10. 65-70kg		

Each contestant deemed to be taking part of his/her own free will, and responsible for himself/herself, shall be allowed to compete in only one weight category: the one corresponding to his weight at the time of the official weigh-in. For categories in the senior age group, competitors may opt for the next higher category than their body weight, except for the heavy weight category, for which contestants must weigh over 96kg for men and over 67kg for women.



FEDERATION INTERNATIONALE DES LUTTES ASSOCIEES
INTERNATIONAL FEDERATION OF ASSOCIATED WRESTLING STYLES

Adresse : Rue du Château 6 / 1804 Corsier-sur-Vecvey / Suisse
Téléphone : (41.21) 312 84 26 Fax : (41.21) 323 60 73 E-mail : fila@fila-wrestling.com Internet : www.fila-wrestling.com

Competitions

International competitions for the various age categories are as follows:

Schoolboys 14-15 years	International competitions	(bilateral and regional)
Cadets 16-17 years	International competitions Continental Championships	(each year)
Juniors 18-20 years	International competitions Continental Championships World Championships	(each year) (each year)
Seniors 20 and older	International competitions Continental Championships Continental Cups World Championships World Cups Golden Grand Prix Challenge match International Grand Prix Super Stars matches Olympic Games	(each year) (each year) (each year, except Olympic year) (each year) (each year) (every four years)
Veterans 35 and older	Competitions according to the programme (each year) Categories, and specific regulations	

CHAPTER 2 – COMPETITIONS AND PROGRAMMES

Article 8 – Competition System

The competitions take place by direct elimination system with an ideal number of wrestlers, i.e. 4, 8, 16, 32, 64, etc. If there is no ideal number of wrestlers in a category, qualification matches will take place.

Pairing is made in the order of the numbers drawn at random. All wrestlers who lost against both finalists will have repechage matches. There are two separated groups of repechage: one group of wrestlers who lost against the first finalist, and another group of wrestlers who lost against the second finalist. The repechage matches begin with wrestlers who lost in the first round including in matches to obtain the ideal number against one of the two finalists up to the losers in the semi-finals by direct elimination. The winners of the two repechage groups will receive each the bronze medal.

Each weight category begins and ends in a day. Each category weigh-in takes place the day before the beginning of the category concerned.

The competition takes place in the following manner:

- Qualification rounds
- Elimination rounds
- Repechage rounds
- Finals



FEDERATION INTERNATIONALE DES LUTTES ASSOCIEES
INTERNATIONAL FEDERATION OF ASSOCIATED WRESTLING STYLES

If there are less than 6 wrestlers in a weigh-in category, the Nordic round will take place (each wrestler against each wrestler).

Example of a competition by direct elimination

Let us take the example of a competition with 22 wrestlers in a weight category. The 22 wrestlers draw a number at random from 1 to 22.

In our example, we have 6 wrestlers with the ideal number of 16. The qualification matches will be disputed by 6 wrestlers who drew the highest numbers after 16, i.e. 17, 18, 19, 20, 21 and 22 and by 6 wrestlers drawing the numbers at random directly before 17, i.e. 16, 15, 14, 13, 12, 11. According to the pairing principle in the order of the numbers drawn at random, the matches take place in the following manner:

- Number 11 against number 12, match number 1
- Number 13 against number 14, match number 2
- Number 15 against number 16, match number 3
- Number 17 against number 18, match number 4
- Number 19 against number 20, match number 5
- Number 21 against number 22, match number 6

The winners of these 6 qualification matches are qualified for the elimination round by direct elimination.

We have the ideal number of 16 wrestlers after the qualification matches. The 16 wrestlers competing for the elimination round are the 10 wrestlers who drew the numbers from 1 to 10 and the 6 wrestlers who won the qualification matches, i.e. numbers 12, 13, 15, 17, 19 and 22 (to arrive at 16). According to the pairing principle in the order of the numbers drawn at random, the first elimination round takes place in the following manner:

- Number 1 against number 2, match number 1
- Number 3 against number 4, match number 2
- Number 5 against number 6, match number 3
- Number 7 against number 8, match number 4
- Number 9 against number 10, match number 5
- Number 12 against number 13, match number 6
- Number 15 against number 17, match number 7
- Number 19 against number 22, match number 8

As mentioned above, all the wrestlers losing against the two finalists will make up a repechage. The wrestlers losing against the finalist no 5 are as follows:

- Number 6 (1st round loser)
- Number 7 (2nd round loser)
- Number 3 (3rd round loser)

The wrestlers losing against the finalist no 15 are:

- Number 16 (qualification round loser)
- Number 17 (1st round loser)
- Number 19 (2nd round loser)
- Number 12 (3rd round loser)



FEDERATION INTERNATIONALE DES LUTTES ASSOCIEES
INTERNATIONAL FEDERATION OF ASSOCIATED WRESTLING STYLES

Adresse : Rue du Château 6 / 1804 Corsier-sur-Vevey / Suisse
Téléphone : (41.21) 312 84 26 Fax : (41.21) 323 60 73
E-mail : fila@fila-wrestling.com Internet : www.fila-wrestling.com

The repechage phase begins with the wrestlers who lost against the finalists at the lowest level of competition.

1st match: n°6 (1st round loser) against n°7 (2nd round loser)
2nd match: n°6 (1st match winner) against n°3 (3rd round loser)

The wrestler n°6 is the winner in the repechage group who lost against the n°5 finalist.

The same system applies to the wrestlers losing against the n°15 finalist.

1st match: n°16 (qualification round loser) against n°17 (1st round loser)
2nd match: n°16 (the winner of the 1st match) against n°19 (2nd round loser)
3rd match: n°16 (2nd match winner) against n°12 (3rd round loser)

The n°16 wrestler is the winner of the repechage group who lost against the n°15 finalist.

The two finalists in the elimination rounds, i.e. n°5 and 15, take part in the match for the 1st and 2nd places. The two winners of the two last repechage matches (n°6 and n°16) receive each the bronze medal. The losers of both finals for the two bronze medals will be ranked 5th ex aequo.

Classification criteria

From the 7th place, wrestlers of each category will be ranked depending on their ranking points, retirement or forfeit, injury or disqualification. In case of a ranking tie, they will be ranked by analysing the following criteria successively:

- The most victories by "Fall"
- The most match won by superiority
- The most period won by superiority
- The most technical points scored in all the competition
- The fewest technical points given in all the competition

If the place of the wrestlers cannot be determined with the above mentioned criterion, they will be ranked ex aequo.

The wrestlers taking part in the repechage phase will also be ranked according to the ranking points earned during the competition, including qualification matches and repechage.

N.B. Disqualified wrestlers for brutality or unfair behaviour will be eliminated and not classified. Except with a medical certificate controlled by a FILA Doctor, if a wrestler does not present himself to the mat for whatever reason as soon as the competition has started, his opponent(s) will win the match, and the wrestler will be eliminated and not classified.

Ranking criteria for the Nordic tournament

Only 4 classification points will be allocated for the victory by fall, default, forfeit, or disqualification in the Nordic tournament system.

In the Nordic tournament, the wrestler with the highest number of victories will be ranked first, regardless of the total number of classification points.

If two wrestlers have an equal number of classification points, their direct match will determine the winner. The wrestler who won against his opponent will be ranked before the other one.

If more than two wrestlers have an equal number of classification points, the last of the ex-aequo group will be determined following these criteria until only two wrestlers remain:



FEDERATION INTERNATIONALE DES LUTTES ASSOCIEES
INTERNATIONAL FEDERATION OF ASSOCIATED WRESTLING STYLES

- The fewest victories by « Fall »
- The fewest match victories by superiority
- The fewest period victories by superiority
- The fewest technical points scored in the whole competition
- The most technical points received in the whole competition

When only two wrestlers remain, their direct match will determine the winner.

Article 9 – Competition Programme

The duration of Olympic Games is 8 days on 3 mats.

The duration of the senior and junior World Championships is 6 days for the three styles (FS, GR, FW) on 3 mats. However depending on the number of entries received, one mat can be added or withdrawn for all competition types with FILA's agreement.

In principle, for all competition types, the matches shall not last longer than three hours. For all competition types, a weight category begins and ends after maximum one day.

For each competition round a weight category must in principle take place on the same mat and not on several mats at the same time. All the matches for the 1st, 2nd and 3rd places must take place on one mat.

Article 10 – Award Ceremonies

The first four wrestlers in each weight category shall take part in the awards ceremony, and shall receive a medal and a diploma, according to their ranking.

1st	Gold
2nd	Silver
The two 3rd	Bronze
5 th -10 th	Diploma

At the World Championships, the winner will receive the World Championship Belt. (See Rules governing distinctions and awards).

Awards ceremonies take place immediately after the final match of the category concerned.

CHAPTER 3 – COMPETITION PROCEDURE

Article 11– Weigh-In

The final list of contestants must be submitted to the organiser by the team leader, without fail, 6 hours before the start of the weigh-in. No changes will be accepted after this time.

The weigh-in for each category always takes place on the day before the beginning of the competition concerned and lasts 30 minutes. For all competitions, a single weigh-in by weight category shall take place.



FEDERATION INTERNATIONALE DES LUTTES ASSOCIEES
INTERNATIONAL FEDERATION OF ASSOCIATED WRESTLING STYLES

Adresse : Rue du Château 6 / 1804 Corsier-sur-Vevey / Suisse **Téléphone** : (41.21) 312.84.26 **Fax** : (41.21) 323.60.73 **E-mail** : fila@fila-wrestling.com **Internet** : www.fila-wrestling.com

No wrestler may be accepted at the weigh-in if he has not undergone a medical examination within the time period stipulated in the Regulations governing the competition in question. Medical examinations are always performed one (1) hour before the weigh-in. Wrestlers must turn up at the medical examination and the weigh-in with their licence and passport, or with their accreditation card alone if the identity control took place at accreditation.

The contestants will be weighed with only their singlet, after having been examined by qualified physicians who are obliged to eliminate any wrestler who presents any danger of contagious disease. No weight tolerance will be allowed for the singlet.

Contestants must be in perfect physical condition, with their fingernails cut very short.

Throughout the entire weigh-in period, wrestlers have the right, each in turn, to get on the scale as many times as they wish.

Referees responsible for the weigh-in must check that all the wrestlers fulfil all the requirements of Article 5 – Competitor’s Dress and to inform any wrestler of the risk he runs if he presents himself on the mat in incorrect dress. Referees will refuse to weigh a wrestler who is not dressed correctly.

Article 12 – Drawing of Lots

Participants shall be paired off for each round according to the numerical order determined by the drawing of lots during the weigh-in. The drawing of lots must be conducted in public. The Heracles software shall be used for the weigh-in and management of all international competitions entered in the FILA calendar.

If the Heracles software cannot be used, numbered tokens corresponding to the number of wrestlers who underwent a medical examination must be enclosed in an urn, a bag or any other similar object. If a different system is used, it must be clear.

The wrestler shall be weighed, and, as he leaves the scales, shall draw his number, on the basis of which he shall be paired off. This number must be immediately entered on a notice board visible to the public, as well as on the starting and weigh-in list.

Important: When the person responsible for the weigh-in and drawing of lots observes an error in the regulation procedure as outlined above, the drawing of lots for the category in question is to be cancelled. Drawing of lots for this category will then be repeated with the agreement of the technical delegate.

Article 13 – Starting List

If one or more wrestlers do not attend the weigh-in or are too heavy, after the weigh-in, wrestlers are regrouped in a precise classification order from the lowest to the highest number.

Article 14 – Pairing

Wrestlers shall be paired off in the order of the numbers they drew. A document establishing the correct procedure and time schedule of the bouts must be drawn up, and it must provide all the relevant information concerning the manner in which the competition is to be conducted.

The pairing for each round, as well as the results, are recorded on a board for use by the competitors, who must be able to consult it at all times. See table enclosed with these rules.



FEDERATION INTERNATIONALE DES LUTTES ASSOCIEES
INTERNATIONAL FEDERATION OF ASSOCIATED WRESTLING STYLES

Adresse : Rue du Château 6 / 1804 Corsier-sur-Vevey / Suisse **Téléphone** : (41.21) 312 84 26 **Fax** : (41.21) 323 60 73 **E-mail** : fila@fila-wrestling.com **Internet** : www.fila-wrestling.com

Article 15 – Elimination from the Competition

The loser is eliminated and ranked according to the classification points marked, except wrestlers who lost against one of the finalists as they take part in the repechage for the 3rd or 5th places.

After the weigh-in, if a wrestler, without medical advice signed by two FILA doctors, does not present himself to his opponent when his name is called is disqualified and not placed. His opponent will win the match.

If the FILA doctors can prove that a wrestler simulates an injury for Political reasons so he doesn't have to wrestle with his opponent, all the wrestlers' team of the concerned style will be eliminated and their opponents will win the match.

If a wrestler commits an obvious offence against fair play within the spirit and concept of total and universal wrestling enunciated by FILA, and openly cheats, commits a serious error or engages in brutality, he will be disqualified immediately from the competition and eliminated by a unanimous decision of the officiating team. In this situation, he will not be placed.

If two wrestlers are disqualified for brutality during the same match, they will be eliminated as above. The pairing for the following round will not be modified. The wrestler supposed to meet one of the disqualified wrestlers wins the match.

If this qualification perturbs the ranking in a final match, the following wrestlers will move up the table to establish the final classification.

If the two finalists are disqualified, then it will be necessary to make the bout between the two bronze medallists to determine the 1st and the 2nd place. All others participants will go up in the ranking, the two in 5th position will become 3rd.

Ranking in the event of doping violations

If the 1st or 2nd ranked wrestler is disqualified for doping, the bronze medallist who lost by elimination from the repechage group of that particular finalist shall move up to second place.

The loser of the repechage group from the finalist disqualified shall move up and will receive the bronze medal. For the rest of the ranking, the other wrestlers will move up in placing according to the ranking system.

In case of positive doping control, the wrestler will be disqualified, and not placed.

CHAPITRE 4 – REFEREEING BODY

Article 16– Composition

In all competitions, the refereeing body for each bout shall consist of the following:

- 1 mat chairman
- 1 referee
- 1 judge



FEDERATION INTERNATIONALE DES LUTTES ASSOCIEES
INTERNATIONAL FEDERATION OF ASSOCIATED WRESTLING STYLES

Adresse : Rue du Château 6 / 1804 Corsier-sur-Vevey / Suisse **Téléphone** : (41.21) 312.84.26 **Fax** : (41.21) 323.60.73 **E-mail** : fila@fila-wrestling.com **Internet** : www.fila-wrestling.com

The appointment procedures of these three officials are set in the Regulations for the International Refereeing Body. Replacement of an official during a bout is strictly prohibited, except in the case of a serious illness that is medically confirmed. In no case may the refereeing body be composed of two officials of the same nationality. Furthermore, it is strictly forbidden for an official to officiate in bouts involving compatriot wrestlers.

The refereeing body shall make all decisions unanimously or by majority of two on one, except in fall situations where the mat chairman's approval must be obtained. It cannot use video evidence to make its decisions (except in case of challenge).

Jury of Appeal

The Jury of Appeal is a group of refereeing experts whose function is to make sure that the wrestling rules are strictly applied during all major FILA events, such as: the Olympic Games, the World and Continental Championships, the World Cups, the Golden Grand Prix tournaments, and the specific Games.

Article 17 – General Duties

a) Officials shall perform all the duties set forth in the Regulations governing wrestling competitions and in any special provisions which might be established for the organisation of particular competitions.

b) It is the duty of officials to follow each bout very carefully and to evaluate the actions of the wrestlers so that the results shown on the judge's score sheet accurately reflect the specific nature of said bout.

c) The mat chairman, referee and judge shall evaluate the holds individually in order to arrive at a final decision. The referee and judge must work together under the direction of the mat chairman, who coordinates the work of the officials.

d) It is the duty of the officials to assume all of the functions of refereeing and judging, to award points and to impose the penalties stipulated in the Rules.

e) The score sheets of the judge and mat chairman are used to tally all the holds executed by the two opponents. The points, cautions (0) must be recorded with the greatest accuracy, in the order corresponding to the various phases of the bout. These score sheets must be signed by the judge and mat chairman, respectively.

f) If a period does not end in a "fall", the decision shall be made by the mat chairman. It shall be based on an evaluation of all the actions of each competitor, recorded from beginning to end on the judge's and mat chairman's score sheets.

g) All the points awarded by the judge must be announced to the public as soon as they are determined, either by means of bats or by an electric scoreboard.

h) Officials are required to use the basic FILA vocabulary that is appropriate to their respective roles when conducting the bouts. However, they are forbidden to speak to anybody during the bout, except, of course, amongst themselves when the occasion requires them to do so for consultation and to perform their tasks properly.

i) When a challenge is requested by a coach and confirmed by the wrestler, the refereeing body must watch the video evidence on big screen at same time as the Jury of Appeal, without leaving their



FEDERATION INTERNATIONALE DES LUTTES ASSOCIEES
INTERNATIONAL FEDERATION OF ASSOCIATED WRESTLING STYLES

seats. After having reviewed the action once, both the refereeing body and the Jury of Appeal must announce its decision.

Article 18 – Referee’s Dress

The refereeing body (referees, judges, mat chairmen, and jury members) must be dressed in the following manner when exercising their function:

- Classic navy jacket with FILA logo
- Grey trousers (no turn-ups) with a black belt
- Long or short sleeved light blue shirt
- Yellow tie with the FILA logo
- Black socks
- Black plimsolls

The dress must be a model homologated by FILA. The refereeing body may not wear the name of a sponsor. However, the number on his jacket may include the name of a FILA sponsor.

Article 19 – The Referee

a) The referee is responsible for the orderly conduct of the bout on the mat, which he must direct according to the Rules.

b) He must command the respect of the contestants and exercise full authority over them so that they immediately obey his orders and instructions. Similarly, he must conduct the bout without tolerating any irregular and untimely outside interventions.

c) He shall work in close co-operation with the judge and must carry out his duties in supervising the bout while refraining from any impulsive or untimely interference. His whistle shall begin, interrupt and end the bout.

d) The referee shall order the return of the wrestlers to the mat after they have left it, or the continuation of the bout in the standing or "par terre" position (on the mat), with the approval of the judge, or failing that, with the approval of the mat chairman.

e) The referee is required to wear a red wristband on his left arm, and a blue wristband on his right arm. He shall indicate with his fingers the points corresponding to the value of a hold after its execution (if it is valid, if it has been executed within the limits of the mat, and if a wrestler has been put in a danger position, etc.) by raising the arm corresponding to the wrestler who scored.

f) The referee must never hesitate to:

- Interrupt the bout at exactly the right time, neither too soon nor too late.
- Indicate whether a hold executed at the edge of the mat is valid.
- Visibly count the five seconds during which the wrestler is held in a bridge position and award the additional point (1) for this situation.
- Signal and announce TOUCHE (fall) after seeking the agreement of the judge, or if this is not possible, of the mat chairman. In order to determine whether a wrestler has actually been pinned to the mat by both shoulders at the same time, the referee must say the word TOUCHE (fall), raise his hand to secure the agreement of the judge or the mat chairman, strike the mat with his hand and then blow the whistle.



FEDERATION INTERNATIONALE DES LUTTES ASSOCIEES
INTERNATIONAL FEDERATION OF ASSOCIATED WRESTLING STYLES

g) The referee must:

- Rapidly and clearly order the position in which wrestling must be resumed, when he sends the wrestlers back to the centre of the mat (their feet must be in the central circle).
- Not stand so close to the wrestlers that he obstructs the view of the judges and the mat chairman, particularly if a fall appears imminent.
- Ensure that the wrestlers do not rest during the bout on the pretence of wiping their bodies, blowing their noses, pretending to be injured, etc. In this case, he must stop the bout and ask for a caution (0) to the wrestler at fault and 1 point to his opponent.
- Be able to change his position from one moment to the next, on the mat or around it, and in particular, immediately fall flat onto his stomach to obtain a better view of an imminent fall.
- Be able to stimulate a passive wrestler without interrupting the bout, by standing in such a way as to prevent the wrestler from leaving the mat.
- Be ready to whistle if the wrestlers come too close to the edge of the mat.
- Not interrupt the bout in Greco-Roman Wrestling in a danger position situation.

h) The referee is also required to:

- Pay special attention to the wrestlers' legs in Greco-Roman wrestling.
- Require the wrestlers to remain on the mat until the result of the bout is announced.
- In all cases where agreement is necessary, first ask the opinion of the judge at the edge of the mat facing the mat chairman.
- Proclaim the winner after agreement with the mat chairman after each period and at the end of the bout.

i) The referee requests penalties for violation of the Rules or for brutality.

j) The referee, if the mat chairman intervenes, must interrupt the bout and proclaim victory by technical superiority when the wrestlers' scores are 7 points difference. In this situation, he must wait for the action - either an attack or a counter attack - to be complete.

Article 20 – The Judge

a) The judge is responsible for all the duties stipulated in the general Rules of wrestling.

b) He must follow the course of the bout very closely without allowing himself to be distracted in any way; he must award points for each action, and mark them on his score sheet, in agreement with the referee or mat chairman. He must give his opinion in all situations.

c) Following each action, and on the basis of the referee's indications (which he compares with his own evaluation) or, failing this, on the basis of the mat chairman's indications, he records the number of points awarded to the action in question, and enters the results on a scoreboard placed beside him. This scoreboard must be visible to both the spectators and wrestlers.

d) The judge verifies and signals the fall (TOUCHE) to the referee.

e) If, during the bout, the judge notices something that he feels he should bring to the referee's attention because the latter was not able to see it or did not notice it (a fall, illegal hold, passive position, etc.), the judge is obliged to do so by raising the bat of the same colour as the singlet of the wrestler in question, even if the referee has not asked for his opinion. In all circumstances, the judge must call the referee's attention to anything that seems to him abnormal or irregular in the course of the bout or in the conduct of the wrestlers.



FEDERATION INTERNATIONALE DES LUTTES ASSOCIEES
INTERNATIONAL FEDERATION OF ASSOCIATED WRESTLING STYLES

Internet : www.fila-wrestling.com

E-mail : fila@fila-wrestling.com

Fax : (41.21) 323 60 73

Téléphone : (41.21) 312 84 26

Adresse : Rue du Château 6 / 1804 Corsier-sur-Vevey / Suisse

f) The judge must, moreover, sign the score sheet handed to him upon receipt, and at the end of the bout, must clearly record on the score sheet the result of the bout by distinctly crossing out the name of the loser and writing in the name and country of the winner.

g) The decisions of the referee and judge are valid and enforceable without the intervention of the mat chairman if they are in agreement - except for proclamation of victory by technical superiority, in which case the mat chairman is required to give his opinion and in case of consultation or challenge.

h) The judge's score sheet must accurately indicate the time at which a bout ends in the case of victory by a fall, technical superiority, withdrawal, etc.

i) To make it easier for the judge to supervise the bout, particularly in a delicate position, he is authorised to change positions, but only along the edge of the mat over which he has control.

j) He must also indicate by underlining, the last action scored which can determine the winner of the period.

k) Cautions for fleeing the mat, illegal holds, or brutality will be noted by an 'O' in the column of the wrestler at fault.

Article 21 – The Mat Chairman

a) The mat chairman, whose functions are very important, shall assume all the duties provided for in the Wrestling Rules.

b) He shall co-ordinate the work of the referee and the judge.

c) He is obliged to follow the course of the bouts very carefully, without allowing himself to be distracted in any way, and to evaluate the behaviour and action of the other officials according to the Rules.

d) In the event of any disagreement between the referee and judge, his task is to settle the issue in order to determine the result, the number of points and the falls.

e) In no case may the mat chairman be the first to give an opinion. He must wait for the opinion of the referee and judge. He is not entitled to influence the decision.

f) The mat chairman's approval must absolutely be sought before granting a fall.

g) The mat chairman may decide to interrupt the bout in case of a serious mistake made by the referee.

h) He may also interrupt the bout if a serious scoring mistake is made by the referee and judge. In such case, he must ask for a consultation. If the mat chairman does not obtain majority during the consultation, he must stand for either the referee or judge. This consultation does not alter the wrestler's right to the challenge.

i) During a bout, when the coach considers that a **blatant refereeing mistake** has been made against his wrestler and calls for a challenge, the mat chairman must wait for the action to go to neutral and stop the match. He must review the video evidence at the same time as the referee, judge, and Jury of Appeal. If the Jury of Appeal agrees that the refereeing body was right, the mat chairman must make sure that no other challenge will be granted to the wrestler in question during the remaining of the match.



FEDERATION INTERNATIONALE DES LUTTES ASSOCIEES
INTERNATIONAL FEDERATION OF ASSOCIATED WRESTLING STYLES

After a single review of the video evidence, the Jury of Appeal renders its decision first, the referee gives his decision next, followed by the judge and the mat chairman. If the Jury of Appeal panel agrees unanimously, its decision is final and cannot be challenged. If there is disagreement among the Jury of Appeal, there may be one final review.

Article 22 – The Jury of Appeal

The Jury of Appeal is formed by the FILA's officiating commission or its or his substitute. It is comprised of three (3) persons chosen among the Instructors, the Bureau members, or knowledgeable refereeing people according to the different matches and wrestlers' nationality. There is one Jury of Appeal per mat.

The Jury of Appeal is responsible for controlling that all rules governing a wrestling match have been applied by the refereeing body before the winner of the period or the match can be declared by the mat chairman.

One member of the Jury of Appeal will be appointed as coordinator and will be in charge of announcing the Jury's decisions on behalf of all.

If the Jury of Appeal notices that a serious administrative, timing or scoring mistake has been made, the coordinator must bring it to the mat chairman's attention and ask for its rectification. If the Jury of Appeal notices that the mat chairman did not stop the match further to a challenge request, the coordinator must ask him to do so immediately after the action is completed.

During the video review, the Jury of Appeal must make its decision and cannot speak with the refereeing body that also must make its decision on its own. If the majority of the Jury of Appeal reaches an unanimous agreement it will be considered final and irrevocable. No further appeal will be possible.

A complete set of red, blue and white paddles must be made available to each Jury of Appeal in order for its decision to be seen by the audience.

No further appeal can be lodged to the FILA Bureau, CAS, or any other court once a decision has been made by the refereeing body (agreed upon by the mat chairman) or by the Jury of Appeal.

The FILA Bureau can eliminate a member of the refereeing body or Jury of Appeal at any time if it deems that a serious mistake in the application of the rules or in the decision of a challenge has been made.

The Jury of Appeal will also be in charge of assessing the referees' work and submitting its written evaluations to FILA.

Under no circumstances should anyone – including FILA Bureau members, FILA delegates, coaches, wrestlers or team leaders - attempt to interfere or influence the Jury of Appeal. Any persons violating this rule shall be expelled from the field of play for the duration of the tournament.

Article 23 – Penalties against the Refereeing Body

The FILA Bureau, which constitutes the supreme jury, shall have the right to take the following disciplinary measures against the official(s) technically at fault:

- Give the official(s) concerned a caution
- Withdraw the official(s) from the competition



FEDERATION INTERNATIONALE DES LUTTES ASSOCIEES
INTERNATIONAL FEDERATION OF ASSOCIATED WRESTLING STYLES

- Demote the official(s) to a lower category
- Order a temporary suspension
- Order a final dismissal

CHAPTER 5 – THE BOUT

Article 24 – Duration of the Bout

For schoolboys and cadets: two periods of 2 minutes with a 30-second break.

For Juniors and Seniors: two periods of 3 minutes with a 30-second break.

For all the competitions, the timing displayed on the scoreboards will start from 0 to 3 minutes (from 0 to 2 minutes for schoolboys and cadets)..

The winner is declared by the addition of the points in both periods. Evident superiority of 7 points automatically leads to victory. The fall stops automatically the match whatever the period.

Freestyle and Female wrestling: The duration of a period is 3 minutes. If, after 2 minutes in the first period, no wrestler has scored then the referee must obligatorily designate the passive wrestler.

Greco-Roman wrestling: The duration of a period is 3 minutes. In the case where a bout ends by 0-0, the victory goes to the wrestler has been lastly the most active.

Article 25 – Call to the Mat

The contestants are called in a loud and clear voice to present themselves on the mat. A contestant cannot be called to compete in a new bout until he has had a rest period of 15 minutes from the time his preceding bout ended.

A delay is granted to any wrestler who does not reply to the first request in the following manner: The competitors must be called three times at 30-second intervals. If the wrestler does not come forward after the third call, he will be disqualified and will not be placed. These calls are made in both French and English. His opponent will win the bout by default.

Article 26 – Presentation of Wrestlers

The following ceremony takes place for each weight category in the finals for first and second places: The finalists are presented on the mat. The speaker announces their achievements during the bout.

Article 27 – Start

Before the bout begins, each opponent answers when his name is called and takes his place at the corner of the mat assigned to him. The corner is the same colour as the singlet he has been assigned to wear.



FEDERATION INTERNATIONALE DES LUTTES ASSOCIEES
INTERNATIONAL FEDERATION OF ASSOCIATED WRESTLING STYLES

The referee, standing in the central circle in the middle of the mat, calls the two wrestlers to his side. He then shakes hands with them and examines their dress, checks that they are not covered with any greasy or sticky substance, verifies that they are not perspiring, verifies that their hands are bare with trimmed nails, and that they have a handkerchief.

The wrestlers greet each other, shake hands and, when the referee blows his whistle, they start the bout.

Article 28 – Interrupting the Bout

a) If a contestant finds himself forced to interrupt the period because of an injury or because of any other acceptable incident beyond his control, the referee may stop the bout. During such an interruption, the wrestler(s) must stand in their corner. They can cover their shoulders with a towel or their dressing gown and receive advice from their coach.

b) If a bout cannot be resumed for medical reasons, the decision is made by the competition doctor in charge, who informs both the coach of the wrestler involved and the mat chairman; the latter then orders that the bout be stopped.

c) Under no circumstances may a contestant take the initiative to interrupt the action himself, by deciding to wrestle in the standing or "par terre" position, or by pulling his opponent back from the edge of the mat to the centre.

d) If an action must be stopped due to one wrestler deliberately injuring his opponent, the wrestler at fault will be disqualified and without any blood injury, 1 point will be allocated to his opponent.

e) If a wrestler interrupts the bout without an blood or visible injury, 1 point will be awarded to the opponent.

Article 29 – End of the Bout

The bout ends either when a fall, a disqualification by injury of one of the opponents are declared, or at the end of the regular time.

A match ends either by technical superiority (7 points difference), or after the execution of a «grand amplitude» 5-point hold (only if after the points are included in his/her score the wrestler is winning), or after the execution of two 3-point holds (only if after the points are included in his/her score the wrestler is winning).

When a wrestler executes a 5-point hold within the regular time, the referee must wait for the possible fall. The second 3-point hold may be followed by a counter-attack if executed in continuity with the action and may end up with a fall.

If the referee has not heard the gong, the mat chairman must intervene and stop the bout by throwing a soft object on the mat, in order to attract the referee's attention. Any action begun at the time when the gong sounds is not validated and no action performed between the sounds of the gong and the referee's whistle is valid.

When the bout has ended, the referee stands in the centre of the mat facing the mat chairman's table. The wrestlers shake hands, stand on either side of the referee and await the decision. They are forbidden to lower the shoulder straps of their singlet before leaving the competition hall. Immediately after the decision is announced, the wrestlers shake hands with the referee.



FEDERATION INTERNATIONALE DES LUTTES ASSOCIEES
INTERNATIONAL FEDERATION OF ASSOCIATED WRESTLING STYLES

Adresse : Rue du Château 6 / 1804 Corsier-sur-Vevey / Suisse
Téléphone : (41.21) 312 84 26 Fax : (41.21) 323 60 73 E-mail : fila@fila-wrestling.com Internet : www.fila-wrestling.com

Each wrestler must then shake hands with his opponent's coach. If the above provisions are not observed, the wrestler at fault will be penalised in accordance with the Disciplinary Regulations.

Article 30 – Interrupting and Continuing the Bout

When the wrestling has been stopped in standing or “par terre” position, it will recommence standing. Wrestling must be stopped and resumed at the centre of the mat in the standing position if:

- One foot entirely touches the protection area.
- The wrestlers in a hold go into the red zone with three or four feet without executing the hold and stay there.
- If the bottom wrestler's head entirely touches the protection zone.

If an attacked wrestler takes an illegal action in the “par terre” position, he will receive a caution and 1 or 2 points will be attributed to his opponent. The bout resumes in “par terre” position, without considering if the wrestler has succeeded or not in his hold.

When a challenge is requested by a coach, the mat chairman interrupts the bout when the action is back to neutral.

Article 31 – Types of Victories

A bout may be won by:

- by "fall"
- by injury, withdrawal, default, disqualification of the opponent
- by technical superiority
- by points (winning by 1 point more at minimum after addition of the two periods)

If the wrestler executes a «grande amplitude» 5-point hold, the points are scored and the match ends (only if after the points are included in his/her score the wrestler is winning).

If the wrestler executes two 3-point holds in the period, the points are scored and the match ends (only if after the points are included in his/her score the wrestler is winning).

In case of tie by points, the winner will be declared by successively considering the amount of cautions, the value of holds, and the last technical point(s) scored (see layout below).



FEDERATION INTERNATIONALE DES LUTTES ASSOCIEES
INTERNATIONAL FEDERATION OF ASSOCIATED WRESTLING STYLES

Example :

Red	Blue	Comment	Result
1 1 1	1 1 <u>1</u>	Last technical point scored by the blue wrestler.	Blue winner
1 2	1 1 <u>1</u>	Last technical point scored by the blue wrestler. The red wrestler scored a 2-point hold.	Red winner
0 0 1 1 <u>1</u>	1 1 1 0	Last technical point scored by the red wrestler, but he has two cautions and the blue wrestler has only one.	Blue winner
1 1 1	1 <u>2</u> 0	The blue wrestler scored a 2-point hold which are the last technical points scored, but he has one caution.	Red winner
1 1 <u>1</u> 0	1 2 0	The red wrestler scored the last technical point. Each of the wrestlers has one caution.	Blue winner
1 1 1 0 0	0 0 1 1 <u>1</u>	Each of the wrestlers has two cautions. The blue wrestlers scored the last technical point.	Blue winner

However, in order not to penalize the attacking wrestler, if the last point causing an even score is obtained by a hold which gives 2 points to each of the opponent because the attacking wrestler rolls on his shoulders in the execution of the hold without action from his opponent, the victory will be attributed to the attacking wrestler.

A wrestler receiving 3 cautions on the total periods of a match is disqualified.

Article 32 – The Coach

The coach may remain at the foot of the platform or at least two metres from the edge of the mat during the bout. Except for the assistance he is authorised to give to a doctor who is providing medical attention to his wrestler, the coach is strictly forbidden to influence decisions or to insult the referee or judge. He may only speak to the wrestler. The coach does not have the right to give water or any other substance during the pause or during the match.

If these restrictions are not observed, the referee is obliged to ask the mat chairman to present the coach with a 'Yellow' card (caution); if he persists, the mat chairman will present him with a 'Red' card (elimination). The mat chairman may also present the YELLOW or RED card on his own initiative.

As soon as the red card is given, the mat chairman reports to the competition director and the coach shall be eliminated from the competition and may no longer continue his duties. However, the wrestling team involved shall have the right to obtain the services of another coach. The National Federation of the eliminated coach will be penalized following the dispositions of the Disciplinary and Financial Regulations.

Article 33 – The Challenge

The challenge is the action through which the coach is allowed, on behalf of the wrestler, to stop the action and request the refereeing body to watch the video evidence in case of a disagreement with the call. This possibility is only offered during competitions in which the video control is formally established by FILA and the Organizing Committee.



FEDERATION INTERNATIONALE DES LUTTES ASSOCIEES
INTERNATIONAL FEDERATION OF ASSOCIATED WRESTLING STYLES

Adresse : Rue du Château 6 / 1804 Corsier-sur-Vevey / Suisse
Téléphone : (41.21) 312.84.26 Fax : (41.21) 323.60.73
E-mail : fila@fila-wrestling.com Internet : www.fila-wrestling.com

The coach must request the challenge by throwing a soft object on the mat, immediately after the refereeing body has awarded or failed to award points to the contested situation. If the wrestler disagrees with the coach's decision, the sponge is returned and the match continues.

The organizers also have the obligation to use the Heracles software and to project the video on a big screen (1 per mat) that must be visible from the entire venue. This screen can be either a plasma screen or a white board used with a projector.

Specific points

Each wrestler is entitled to one (1) challenge per match. If after reviewing the challenge either the Jury of Appeal or refereeing body modifies its decision, then the challenge can be used again during the match.

If the Jury of Appeal confirms the decision, the wrestler loses the challenge and his opponent will receive one (1) technical point.

The mat chairman shall demand to stop the match to review the challenge as soon as the situation on the mat becomes neutral.

No challenge can be requested in the event of a fall, being understood that the fall must be confirmed by the mat chairman further to the decision of either the referee or the judge.

No challenge can be requested after the end of the regular time of a period, except if the points are added to the scoreboard after the referee's whistle. The coach has 5 seconds from the time the questioned score is posted on the official scoreboard to request a challenge.

The coach requesting the challenge must do so from his seat, without stepping on the mat or approaching the judge's or the mat chairman's table.

During the review of the challenge, no consultation among the refereeing body is permitted.

After having reviewed the action once, the referee gives his decision first and is immediately followed by the judge who gives his decision from his seat with the material available to him (paddle or electronically). Even if the referee and the mat chairman agree, the Jury of Appeal intervenes and renders its decision in all cases. A unanimous decision by the Jury of Appeal will be final and may not be discussed. If the members of the Jury of Appeal disagree, a second review of the action will be requested. Then the majority decision of the Jury of Appeal will prevail.

It will not possible to request a "counter challenge" once a final decision has been made by the refereeing body or Jury of Appeal.

Article 34 – Team Ranking during Individual Competitions

The team ranking is determined by the first 10 wrestlers who are classified at the competition.

Rank in the weight category	Points	Place dans la catégorie de poids	Points
1st	10	7th	4
2nd	9	8th	3
3rd – 3rd	8	9th	2
5th – 5th	6	10th	1



FEDERATION INTERNATIONALE DES LUTTES ASSOCIEES
INTERNATIONAL FEDERATION OF ASSOCIATED WRESTLING STYLES

The application of the above-mentioned table remains invariable, whatever the number of wrestlers in each category is.

In the event of equal classification of several teams, the team having obtained the most first places is placed first, etc.

Article 35 – Ranking System during Team Competitions

In principle, a team competition takes place according to FILA official weight categories, that is 7 categories. If categories have to be doubled for proper reasons to the country system or team's interest, it is recommended to have always an odd number of categories. Each team may change the wrestlers for each session, as long as they were weighed-in.

If a home-away session takes place in one day, one winner must be declared at the end of the home bout, and one at the end of the away bout. The victory obtained by a wrestler in a match gives 1 point to his team, with no regard to the way the victory has been obtained. This way each match can give a winner with an odd number.

If a competition involves only two teams

If it is a one-day home-away session between two teams, and each team wins a match, they are two ranking possibilities to be determined before the beginning of the match.

- a) Having a third match to determine the winning team.
- b) Determine the winning team by assessing the following criteria:

- The most victories by adding the points of the 2 matches
- The most victories by fall, default, forfeit, or disqualification
- The most match victories by technical superiority
- The most period victories by superiority
- The most technical points obtained in all the competition
- The fewest technical points given in all the competition

If a competition involves more than two teams

The same system will apply to determine the winner of the match. The winning team will receive 1 point and the losing one 0 point.

If two teams have an equal number of classification points at the end of the competition, the winner will be determined on bases of the result of their match.

If three or more teams have an equal number of victories

The following principle will apply to rank the worst team(s):

- The fewest classification points
- The fewest victories by fall, default/forfeit/disqualification
- The fewest match victories by superiority
- The fewest period victories by superiority
- The fewest technical points obtained in all the competition
- The most technical points given in all the competition

The two remaining teams will be ranked according to the result of their direct match.



FEDERATION INTERNATIONALE DES LUTTES ASSOCIEES
INTERNATIONAL FEDERATION OF ASSOCIATED WRESTLING STYLES

CHAPTER 6 – POINTS FOR ACTIONS AND HOLDS

Article 36 – Evaluation of the Importance of the Action or Hold

In order to encourage risk-taking during bouts, when a wrestler tries unsuccessfully to execute a hold and finds himself underneath in a "par terre" position without a move by his opponent, the wrestler above will not be awarded a technical point and both wrestlers will be brought back to their feet immediately. However, if, during a hold, the defending wrestler executes a counterattack and is able to bring his opponent to the ground, he will be awarded the point(s) that correspond to the action.

If the attacking wrestler executes a hold on his own bridge, holds this position for a certain amount of time, and then completes his action by placing his opponent in the bridge position as well, he will not be penalised. Only the attacking wrestler will be awarded the points, as he will have completed the action in a hold that involved risks. However, if the offensive wrestler is blocked under control in the bridge position or by a counteraction by his opponent, it is clear that points will be awarded to the latter wrestler.

Furthermore, the wrestler on whom a hold was initiated may only be awarded points if, by his own action, he has:

- a) Brought the offensive wrestler to the ground.
- b) Conducted the action on a continuous basis.
- c) Succeeded in controlling the offensive wrestler by blocking him in a bridge position, that is, in a position considered completed.
- d) The referee must wait for the end of each situation prior to awarding the point values earned by each wrestler.
- e) In cases where the wrestlers' actions lead them to change from one position to another, the points for all the actions are awarded according to their value.
- f) The instantaneous fall does not exist (article 44). If the wrestler falls instantly from a standing position following a move by his opponent, the attacker receives three points. If the wrestler falls instantly during his own move, his opponent receives two points. When wrestling in the "par terre" position when the wrestler is in the situation of instant fall, his opponent receives two points.
- g) Rolling from one shoulder to the other using the elbows in the bridge position, and vice-versa, is considered to be only one action.
- h) A hold must not be considered to be a new action until the competitors return to the initial position.
- i) The referee will indicate the points. If the judge agrees, he will raise the bat bearing the colour and value in question (1, 2, 3 or 5 points). In the event of any disagreement between the referee and judge, the mat chairman must make a decision in favour of one or the other of the wrestlers; he is not allowed to give a different opinion, except if he calls for a consultation and obtains majority.
- j) In the event of a fall that occurs at the end of regulation time, only the sound of the gong (and not the referee's whistle) is valid.
- k) At the end of a period, any hold is valid if it was completed before the gong sounded. In no event may a hold finished after the sound of the gong be counted.



FEDERATION INTERNATIONALE DES LUTTES ASSOCIEES
INTERNATIONAL FEDERATION OF ASSOCIATED WRESTLING STYLES

Article 37 – Danger Position

A wrestler shall be considered in the 'danger position' when the line of his back (or the line of his shoulders) vertically or in parallel with the mat, forms an angle of less than 90 degrees to the said mat and when he resists with the upper part of his body to avoid a 'fall'. (See definition of 'fall').

The danger position occurs when:

- The defending wrestler assumes the bridge position to avoid being pinned.
- The defending wrestler, with his back toward the mat, supports himself on one or both elbows to avoid having his shoulders forced onto the mat.
- The wrestler has one shoulder in contact with the mat and at the same time exceeds the 90 degree vertical line with the other shoulder (acute angle).
- The wrestler finds himself in the 'instantaneous fall' position, that is, when he is on both shoulders for less than one second.
- The wrestler rolls on his shoulders.

The 'danger position' no longer exists when the wrestler exceeds the 90-degree vertical line with his chest and stomach facing the mat.

If the mat and the competitor's back form a 90-degree angle only, this cannot yet be considered a 'danger position' (the neutral point).

Article 38 – Recording the Points

The judge marks the points obtained for the actions and holds executed by the wrestlers on a score sheet, as each action is performed during the bout.

The points of the action bringing about a fall are to be noted on the score sheet by a circle. The caution for fleeing the mat, fleeing a hold, refusal to start, illegal hold and brutality shall be noted by (0). After each caution (0) the opponent will automatically receive one or two technical points, depending on the gravity of the infraction.

In case of a tie in points, the last technical point scored shall be underlined.

Article 39 – Grand Amplitude Throw

Is considered "Grand amplitude" throw, any action or hold by a wrestler in the standing position that causes his opponent to lose all contact with the ground, controls him, makes him describe a broadly sweeping curve in the air, and brings him to the ground in a direct and immediate danger position.

In the "par terre" position, any complete lift from the ground executed by the attacking wrestler, whether the attacked wrestler lands belly down (3 points) or in a danger position (5 points), is also considered a grand amplitude throw.

NB: If the wrestler executing a grand amplitude hold himself touches the mat with both shoulders, he receives 3 or 5 points and his opponent receives 2 points, due to the instantaneous fall in the execution of the throw.



FEDERATION INTERNATIONALE DES LUTTES ASSOCIEES
INTERNATIONAL FEDERATION OF ASSOCIATED WRESTLING STYLES

Article 40 – Value assigned to the Actions and Holds

1 point

- To the wrestler who applies a correct hold while standing on the mat or in the "par terre" position but who does not place his opponent in danger.
- To the wrestler who blocks his opponent on one or two outstretched arms, his back facing the mat.
- To the wrestler who is prevented from completing a hold because his opponent is maintaining an irregular hold, but who finally succeeds in completing the hold.
- To the attacking wrestler whose opponent flees the hold, the mat, refuses to start, commits illegal actions or acts of brutality.
- To the wrestler who holds his opponent in a position of danger for five seconds or longer.
- To the wrestler whose opponent goes in the protection zone with one entire foot (in standing position).
- All the stops of bout by injury without bleeding or any visible injury are penalised by 1 point to the opponent.
- To the wrestler whose opponent requested a challenge if initial decision is confirmed.

2 points

- To the wrestler who brings his opponent to the ground by passing behind him, and while in this position holding him down with control (three points of contact: two arms and one knee or two knees and one arm or the head).
- To the wrestler who overcomes, holds and controls his opponent by passing behind him.
- To the wrestler who applies a correct hold while wrestling in the "par terre" position and places his opponent in a position of danger or in an instantaneous fall position.
- To the attacking wrestler whose opponent rolls onto his shoulders.
- To the attacking wrestler whose opponent flees the hold by jumping out-of-bounds in a position of danger.
- To the attacking wrestler whose opponent commits an illegal hold that hinders the execution of an engaged hold or a fall
- To the top wrestler whose opponent refuses correct "par terre" position in Greco-Roman ordered hold after a first friendly warning.
- To the defending wrestler if the attacking wrestler goes into the instantaneous fall position or rolls onto his shoulders in executing a hold.
- To the wrestler who blocks his opponent in the execution of a hold from the standing position, in a position of danger.

3 points

- To the wrestler performing a hold in a standing position, which brings his opponent into a danger position by direct projection over a short amplitude.
- For any hold executed by raising a wrestler from the ground, over a short amplitude, even if one or both of the attacking wrestler's knees are on the ground.
- To the wrestler who executes a grand amplitude hold which does not place the opponent in a direct and immediate danger position.

NB. If, in performing a hold, the defending wrestler maintains contact with the mat with one of his hands, but is immediately placed in a danger position, the attacking wrestler will receive 3 points.

5 points

- All grand amplitude throws executed in a standing position which bring the defending wrestler to a direct and immediate danger position.



FEDERATION INTERNATIONALE DES LUTTES ASSOCIEES
INTERNATIONAL FEDERATION OF ASSOCIATED WRESTLING STYLES

- The hold executed by a wrestler in the "par terre" position who completely lifts his opponent off the ground with the execution of a high amplitude throw which projects the opponent into a direct and immediate danger position

Article 41 – Decision and Vote

The referee shall indicate his decision by raising his arm and clearly showing the points with his fingers. If the referee and judge agree, the decision is announced. The mat chairman is not entitled to influence or change a decision if the referee and judge are in agreement except if he calls for a consultation or after a challenge.

If a vote is taken, the judge and mat chairman must indicate their votes using bats or an electric score board. There are 11 bats, painted different colours: blue, red and white, as follows: one white, five red, four of which are numbered 1, 2, 3, 5 to indicate the points and one of which is an unmarked bat intended for cautions and to attract attention to the wrestler concerned, and five blue bats, four of which are numbered as the red bats, with one bat unmarked.

They must be kept within easy reach of those who are to use them. Under no circumstances may the judge abstain from voting. He must express his decision clearly, leaving no room for ambiguity.

In case of a disagreement, the mat chairman makes the decision. This decision, in which he must decide between the opposing opinions of the referee and judge, obliges the mat chairman to vote in all cases for one or the other of the views given.

If the period lasts until the end of the allotted time, the mat chairman's score sheet will be taken into consideration when designating the winner. The public scoreboard must conform to the mat chairman's score sheet at all times during the bout. If there is a difference of 1 or more points between the judge's and mat chairman's score sheets, only the score on the mat chairman's score sheet will be considered.



Article 42 – Decision Table

When observing a wrestling action, the referee and judge award the points, cautions, indicated below which, in each of the cases put forward, provides the following result:

R: Red wrestler – B: Blue wrestler – 0: Zero point

Referee	Judge	Mat Chairman	Official Result	Observations
1R	1R	-	1R	In these examples the judge and referee being in agreement, the mat chairman does not intervene except for serious fault
2B	2B	-	2B	
3R	3R	-	3R	
5R	5R	-	5R	
1R	0	0	0	In these examples the judge and the referee being in disagreement, the mat chairman intervenes and the principle of majority applies
1B	1R	1R	1R	
2R	1R	2R	2R	
2B	0	2B	2B	
3R	2R	2R	2R	
3B	1R	3B	3B	

In the event of any flagrant violation of the Rules, the mat chairman must call for a consultation. At the end of each period the score starts from zero for the following period.

CHAPITRE 7 – CLASSIFICATION POINTS AWARDED AFTER A BOUT

Article 43 – Classification Points

The classification points awarded to a wrestler shall determine his final ranking.

5 points for the winner and 0 for the loser:

- Victory by fall (with or without technical point for the loser)
- Injury
- Withdrawal
- Default
- Disqualification

4 points for the winner and 0 for the loser:

- Victory by technical superiority, with the loser scoring no technical points

4 points for the winner and 1 point for the loser:

- Victory by technical superiority (7-point difference during two periods) with loser scoring technical points.

3 points for the winner and 0 for the loser:

- When during the bout, the wrestler wins two periods of 1 to 5 points with the loser scoring no point.



FEDERATION INTERNATIONALE DES LUTTES ASSOCIEES
INTERNATIONAL FEDERATION OF ASSOCIATED WRESTLING STYLES

3 points for the winner and 1 point for the loser:

- When during two periods the bout ends by a victory by points during regular time and the loser scoring one or several technical points.

0 point for the red wrestler and 0 point for the blue wrestler:

- In case both wrestlers have been disqualified due to infraction to the rules.

Article 44 – The Fall

When the defensive wrestler is held by his opponent with his two shoulders against the mat for a sufficient time to allow the referee to observe the total control of the fall, the resulting manoeuvre is considered to be a fall. For a fall at the edge of the mat to be recognised, the competitor's shoulders must be completely in the red zone and the head must not touch the protection area.

A fall in the protection area is not valid.

If the wrestler is pinned on both shoulders as a consequence of a rule infringement or an illegal hold for which he is responsible, the fall will be considered valid for his opponent.

The fall observed by the referee will be valid if confirmed by the mat chairman. If the referee does not indicate the fall, and if the fall is valid, it may be announced with the consent of the judge and mat chairman.

Consequently, to be observed and recognised, the fall must be clearly maintained. The two shoulders of the wrestler in question must be simultaneously touching the mat during the short period of stoppage specified in the first paragraph, even in the case of a standing rear body lock and lift. In all cases, the referee will strike the mat only after he has obtained confirmation from the judge or, failing this, from the mat chairman. The referee will then blow his whistle in order to end the bout.

It will not be possible to request any challenge in case of a fall, being understood that the fall must be validated by the mat chairman following the judge or the referee's decision.

Article 45 – Technical Superiority

Except from the fall, default, disqualification, the bout must be stopped before the end of regular time regardless of the score when:

- There are 7 points difference between the wrestlers
- A wrestler has scored two 3-point holds (only if after the points are included in his/her score the wrestler is winning)
- A wrestler has scored one 5-point hold (only if after the points are included in his/her score the wrestler is winning)

The bout may not be interrupted to declare the winner by technical superiority until the action is completed (see article 29).

The mat chairman signals the referee when the 7-point difference has been attained. The referee shall declare the winner after consulting with members of the officiating team, for a period or for the match (in which the wrestler won two periods by superiority).



FEDERATION INTERNATIONALE DES LUTTES ASSOCIEES
INTERNATIONAL FEDERATION OF ASSOCIATED WRESTLING STYLES

CHAPITRE 8 – NEGATIVE WRESTLING

Article 46 – Par Terre Position during the Bout

If one of the wrestlers brings his opponent to the ground during the match, wrestling continues in the “par terre” position and the wrestler underneath may counter his opponent’s efforts, stand up or carry out counter-attacks of his choice. If a wrestler brings his opponent to the ground and owing to good defensive action by the attacked wrestler is unable to initiate an action, the referee stops the bout after a reasonable period of time and has the wrestlers resume the bout in a standing position.

The attacking wrestler is forbidden to resume the bout by jumping on his opponent. If he does so, the referee must give him a caution, give 1 point to his opponent, and ask the wrestler in a “par terre” position to stand up again.

The wrestler on top has no right to interrupt the bout nor to request that wrestling resume in a standing position.

Ordering of “par terre” position

The initial position of wrestlers in “par terre” position before the referee blows his whistle is as follows: The wrestler ordered in the “par terre” position must have knees and hands in the centre circle. Distance between his hands and knees shall be at least 20 centimeters. Arms shall be stretched out, feet shall not be crossed, and the superior part of the legs shall be stretched out forming a 90° degree angle with the mat.

The top position wrestler is placed behind his opponent, hands on his shoulders. He can be in a standing position, or have a knee on the floor.

Article 47 – Red Zone

The red zone is provided for the purpose of detecting the passive wrestler; it is also intended to help eliminate systematic wrestling on the edge of the mat and any departures from the wrestling area.

Any hold or action begun on the central wrestling area and ending within that zone are valid including position of danger, counterattack and fall.

Any hold or counter attack begun in the standing position on the central wrestling area of the mat (apart from the red zone) is good, regardless of the place where it finishes (wrestling area, red zone or protection area). However, if it ends in the protection area, the bout is stopped and the wrestlers are returned to the centre of the mat. In the standing position, points will be awarded according to the value of the hold.

A fall in the protection area is not valid. The bout must be interrupted and the wrestlers returned in standing position to the centre of the mat because the hold ended off the mat.

In a case where the attacking wrestler executing the hold arrives in a fall position in the protection zone, the bout shall be stopped and his opponent shall receive two points. The bout shall be resumed in the centre of the mat, in standing position.

In the execution of their started holds and actions, and which have begun on the central surface of the mat, the wrestlers can enter the red zone with three or four feet and continue their actions or holds in all directions, provided that nothing interrupt the execution of their hold (pushing, blocking, pulling).



FEDERATION INTERNATIONALE DES LUTTES ASSOCIEES
INTERNATIONAL FEDERATION OF ASSOCIATED WRESTLING STYLES

An action or a hold may not be commenced in a standing position in the red zone, except under the strict condition that the wrestlers engaged in the hold have only two feet in the zone. In this case, the referee will tolerate the situation for a limited period of time, waiting for the hold to be developed.

If the wrestlers interrupt their action in the red zone and stay there or if without any action they place two, three or four feet there, the referee interrupts the bout and brings the wrestlers back to the centre, the bout resumes in standing position.

In all cases, in standing position, if one of the attacking wrestler's foot is in the protection area, that is outside the red zone, the referee interrupts the bout.

When the defending wrestler's foot is in the protection area, but the attacking wrestler carries out a hold without interruption, the hold is good. If the attacking wrestler does not carry out the hold, the referee interrupts the bout.

When the defending wrestler places one of his foot in the red zone, the referee must call 'ZONE' in a loud voice. Upon hearing this word, the wrestlers must endeavour to return towards the centre of the mat without interrupting their action.

In wrestling in "par terre" position, any action, hold or counterattack executed from or in the red zone is good, even if it ends in the protection area.

The referee and judge will award points for all actions initiated in "par terre" position in the red zone and executed in the protection area. However, the bout will be interrupted and the wrestlers returned to the centre in a standing position.

In wrestling in "par terre" position, the attacking wrestler may continue his action if he moves out of the zone while executing the hold, provided that the shoulders and head of his opponent are within the zone. In this case, even four legs may be off the mat.

Article 48 –Enforcement of Passivity (Freestyle and Greco Roman)

Procedure for enforcement of penalties for inactivity in Freestyle wrestling

The role of the referees, among other vital duties, should be to evaluate and distinguish what is real action versus a feigned attempt to waste time.

- a. Anytime all 3 mat officials agrees a wrestler is blocking, interlocking fingers, thwarting his opponent and/or generally avoiding wrestling: the mat referee signals to the wrestler "*Caution blue or red*". First offence is a verbal warning: "*Attention*". Second offence: the action is stopped briefly to designate the guilty wrestler and a 30-second mandatory-score period begins. A light corresponding to the wrestler at fault is lighted. This notifies the wrestlers, coaches and spectators an "activity period" has begun. Should either wrestler score in the 30 seconds penalty session, no penalty point is awarded, only the corresponding technical point or points. If neither wrestlers scores, the opponent of the designated passive-wrestler is awarded a penalty point and the passive wrestlers receives a caution.
- b. If after 2:00 minutes into the first period neither wrestler has scored, the referees must mandatorily designate one of the wrestler as inactive (the same procedure described above is administered).
- c. If this penalty system is accompanied with the current tie-breaker criteria including last-to-score, all overtimes, flips-of-the-coin, "ball-pulls" and/or "clinches" are eliminated.

Procedure for enforcement of penalties for inactivity in Greco-Roman wrestling

- a. 1st violation: warn the wrestler and notify the mat chairman and “Jury of Appeal”.
- b. 2nd violation results in a caution. The opponent of the cautioned wrestler chooses between “par terre” and “standing” position.
- c. 3rd violation results in a technical point for the opponent of the guilty wrestler. In addition, the active wrestler has the choice of either “par terre” or “standing” position.
- d. 4th violation: the bout is terminated. The active wrestler wins by fall.
- e. Should a bout end 0-0, the victory is awarded to the wrestler who was last to be judged most active. This situation of neither wrestler having been warned for passivity is not contemplated, because it is recommended that the officials define one of the wrestlers as inactive within the 1st minute.

Following the 2nd and 3rd passivity violation in the Greco-Roman discipline, the opponent of the cautioned wrestler has the choice of either par terre or standing position. The wrestler who chooses par terre position has the choice of the side position and lift or the back position, standing or one knee to the mat, with his hands resting on the opponent’s shoulders.

Note: the procedures for the enforcement of passivity for the Freestyle and Greco-Roman disciplines are distinctly different.

Layout for the ordered hold in Greco-Roman:

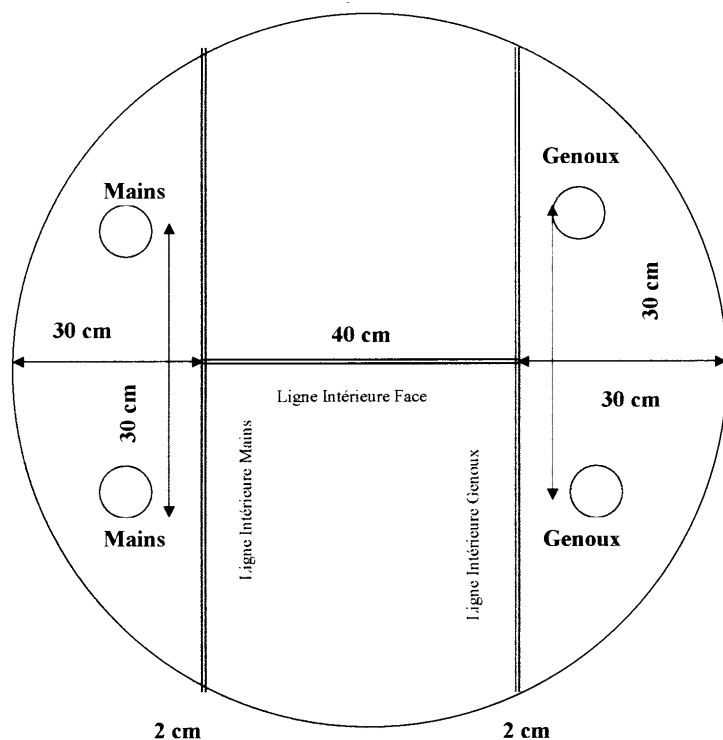

Possibility of position of one foot or two feet on the line. The foot/feet must not go beyond the line.



FEDERATION INTERNATIONALE DES LUTTES ASSOCIEES
INTERNATIONAL FEDERATION OF ASSOCIATED WRESTLING STYLES

In order to execute the ordered hold, the top wrestler grabs the wrestler in the “par terre” position by his waist, with his head towards his opponent’s back, and executes a reverse body-lock, hand on hand or hand in hand. The wrestler, who takes the hold, can be in a standing position or have one knee on the mat.

At the referee’s whistle, he must take hold at once, with both arms and without simulating. In any case, the wrestler cannot push his opponent with his leg or make gestures towards the referee regarding his opponent’s position. If the attacking wrestler simulates or pushes with his legs, the referee must stop the match and warn the wrestler at fault with ATTENTION. If the attacker repeats the violation a second time, the referee must apply the proper sanction by awarding a caution and 1 point to the opponent. Wrestling resumes in standing position.

Once the hold is executed, the referee whistles and the top wrestler can execute the hold. His opponent can start defending himself. During these 30 seconds, both wrestlers can execute all possible actions, in a standing or a “par terre” position.

CHAPTER 9 – PROHIBITIONS AND ILLEGAL HOLDS

Article 49 – General Prohibitions

Wrestlers are forbidden to:

- Pull the hair, ears, genitals, pinch the skin, bite, twist fingers or toes, etc. and generally, to perform actions, gestures or holds with the intention of torturing the opponent or making him suffer to force him to withdraw.
- Kick, head-butt, strangle, push, apply holds that may endanger the opponent’s life or cause a fracture or dislocation of limbs, tread on the feet of the opponent or touch his face between the eyebrows and the line of the mouth.
- Thrust the elbow or knee into the opponent's abdomen or stomach, carry out any twisting action which is likely to cause suffering, or hold the opponent by his singlet.
- Cling to or grasp the mat.
- Talk during the bout.
- Seize the sole of the opponent’s foot (only seizing the upper part of the foot or the heel is permitted).
- Agree the match result between themselves.

Article 50 – Fleeing a Hold

Fleeing a hold occurs when the defending wrestler openly refuses contact in order to prevent his opponent from executing or initiating a hold. These situations arise in both the standing and "par terre" positions. They may occur in the central wrestling area or from the central wrestling area to the red zone. Fleeing a hold shall be penalised in the same way as fleeing the mat, that is:

- 1 caution against the wrestler at fault (0)
- 1 point to the opponent



FEDERATION INTERNATIONALE DES LUTTES ASSOCIEES
INTERNATIONAL FEDERATION OF ASSOCIATED WRESTLING STYLES

Adresse : Rue du Château 6 / 1804 Corsier-sur-Vevey / Suisse
Téléphone : (41.21) 312.84.26 Fax : (41.21) 323.60.73 E-mail : fila@fila-wrestling.com Internet : www.fila-wrestling.com

Fleeing a hold in ground position in Greco-Roman

When a wrestler is on the ground following an action by his opponent or after an ordered hold and he then jumps forward to prevent his being caught for a hold, he puts his opponent in the position of committing an illegal hold - holding the thighs of the "escaping" wrestler, will be considered as a fleeing of a hold. The referee must not allow this situation which is a fleeing the hold offence by the fleeing wrestler. He must therefore be very clear and precise in the manner in which he deals with this offence. He must also place himself in front of the wrestlers in a way to prevent the flee from taking place.

- The first time that the wrestler on the ground jumps forward to avoid being caught by his opponent, the referee must warn aloud "attention, no jump".
- The second time, the referee must request a caution and 1 point for fleeing the hold, stop the match following agreement by the judge and the match chairman, make the wrestlers stand up, signal the offence and restart the match in Standing position.

This method is valid for penalising fleeing the hold when the wrestler jumps forward. However, the defence of moving laterally to avoid a hold is authorised and should not be sanctioned.

The wrestler who is dominated on the ground in Greco-Roman does not have the right to bend or raise either or both of his legs to prevent a hold being executed.

If a dominated wrestler on the ground uses his legs as a defence, he will receive a caution and his opponent 2 points.

Article 51 – Fleeing the Mat

When a wrestler flees the mat, from either a standing or "par terre" position, a caution shall immediately be issued against the wrestler at fault. The following points shall be awarded to the attacking wrestler:

Fleeing the mat:

- 1 point + 1 caution against the opponent

Fleeing the mat in a danger position:

- 2 points + 1 caution against the opponent

All points for fleeing the mat are considered technical points. Also, all fleeing the mat in standing position gives one point to the opponent, whether the wrestler has been pushed outside or not. On the other hand, the action which consists of voluntarily carrying the opponent out of the mat will give 1 caution to the carrying wrestler and 1 point to his opponent.

The standing position consisting of voluntarily maintain the opponent to a distance or to break contact will penalize the faulty wrestler of 1 caution and 1 point will be attributed to his opponent, just like for the hold escape.



FEDERATION INTERNATIONALE DES LUTTES ASSOCIEES
INTERNATIONAL FEDERATION OF ASSOCIATED WRESTLING STYLES

Article 52 – Illegal Holds

The following holds and actions are illegal and strictly prohibited:

- Throat hold
- Twisting of arms more than 90 degrees
- Arm lock applied to the forearm
- Holding the head or neck with two hands, as well as all situations and positions of strangulation
- Double Nelson, if not executed from the side without the use of the legs on any part of the opponent's body
- Bringing the opponent's arm behind his back and at the same time applying pressure to it in a position where the forearm forms an acute angle
- Executing a hold by stretching the opponent's spinal column
- Chancery hold with one or two hands in any direction whatsoever
- The only holds allowed are with the head and one arm
- In standing, holds executed from behind when the opponent is head down (reverse waist hold), the fall must be executed only to the side and never from top to bottom (header)
- In executing a hold, only one arm may be used to hold the opponent's head or neck
- Lifting the opponent who is in a bridge position and then to throw him onto the mat (severe impact on the ground); that is, the bridge must be forced down
- Breaking the bridge by pushing in the direction of the head
- Generally, if the attacking wrestler is found to have violated the Rules during the execution of a hold, the action in question shall be completely void and on the first offence, the referee shall give an "attention" to the attacking wrestler at fault. If the attacker repeats his violation, he will be punished by a caution and one point will be awarded to his opponent.
- If a defending wrestler, by an illegal action, prevents his opponent from developing his hold, the defending wrestler will be cautioned. His opponent will receive two points.

Prohibited holds for female wrestling

All double Nelsons holds in the "par terre" or standing position are forbidden in female wrestling.

Prohibited holds for schoolboys and cadets

To protect the health of young wrestlers, the following holds are considered illegal and prohibited for the schoolboy and cadet categories:

- Double Nelson from both the front and side
- In freestyle, a leg hook on the opponent's leg, in addition to the double Nelson

Referee's duty towards the competitor committing a violation

If the attacking wrestler can carry out the action in spite of an illegal hold of the defending wrestler:

- Stop the violation
- Ask for a caution
- Give 1 point to the opponent
- Give the value corresponding to the hold to his opponent
- Stop the match
- Resume wrestling in the position where the infraction occurred



FEDERATION INTERNATIONALE DES LUTTES ASSOCIEES
INTERNATIONAL FEDERATION OF ASSOCIATED WRESTLING STYLES

If the attacking wrestler cannot carry out his action because of an illegal hold of the defending wrestler

- Stop the match and ask for a caution
- Give two points to his opponent
- Resume wrestling in the position where the infraction occurred

Article 53 – Special Prohibitions

a) In Greco-Roman wrestling, it is forbidden to grasp the opponent below the hips and to squeeze him with the legs. All pushing, pressing or 'lifting' by means of contact with the legs on any part of the body of the opponent is also strictly forbidden.

b) In Greco-Roman, unlike in Free Style Wrestling, it is necessary to accompany the opponent to the ground and to stay in contact with him in order for a hold to be valid.

c) In freestyle, a scissor-lock with the feet crossed on the head, neck or body is forbidden.

Article 54 – Consequences affecting the Bout

The illegal hold of the attacked wrestler shall be stopped by the referee without interrupting the hold if possible. If there is no danger, the referee allows the development of the hold and waits for the result. He then stops the match, gives the points and a caution to the wrestler at fault.

If the hold begins properly and then becomes illegal, the hold should be evaluated up until the beginning of the infraction, then the match should be stopped and wrestling should be made to continue in a standing position with the attacking wrestler receiving an amicable caution. If the wrestler attacks again with an illegal hold, the referee will stop the match, give a caution (0) to the wrestler at fault, one point to his opponent.

In all cases, in the event of any wilful butting with the head or any other brutality, the wrestler at fault may be eliminated immediately from the bout by a unanimous decision of the officiating team, or disqualified from the competition and placed last with a comment "eliminated for brutality".

CHAPITRE 10 – THE PROTEST

Article 55 – The Protest

No protest may be lodged at the end of a match. Under no circumstances may the result of a match be modified after victory has been declared on the mat.

If the FILA President or the responsible person for refereeing notes that the refereeing body have abused their power to modify a match result, they can examine the video and, with the agreement of the FILA Bureau, sanction those responsible as laid down in the provisions of the Regulations for International Refereeing Body.



FEDERATION INTERNATIONALE DES LUTTES ASSOCIEES
INTERNATIONAL FEDERATION OF ASSOCIATED WRESTLING STYLES

CHAPITRE 11 – MEDICAL

Article 56 – Medical Service

As specified in the Regulations defining the international competitor's licence, each wrestler must undergo a medical examination in his own country three days before leaving for Championships, Cups and Games.

The organiser of the competition in question is obliged to provide a medical service responsible for conducting medical examinations prior to the weigh-in and give medical control during the bouts. The medical service, which is required to operate throughout the competition, is under the authority of the FILA doctor in charge.

Before the competitors weigh in, the doctors shall examine the athletes and evaluate their state of health. If a competitor is considered to be in poor health or in a condition that is dangerous to himself or to his opponent, he shall be excluded from participating in the competition.

Throughout the competitions, and at any time, the medical service must be prepared to intervene in case of an accident and to decide whether a wrestler is fit to continue the contest. Doctors from the participating teams are fully authorised to treat their injured wrestlers, but only the coach or a team officer may be present while treatment is being administered by the doctor.

In no case may FILA be held responsible for an injury, disability, or death of a wrestler.

Article 57 – Medical Service Interventions

The FILA doctor in charge has the right and duty to stop a bout at any time through the mat chairman, whenever he considers that either competitor is in danger.

He may also stop a bout immediately by declaring one of the wrestlers unfit to continue. The wrestler must never leave the mat, except in the event of a serious injury requiring his immediate removal. In case of a wrestler being injured, the referee must immediately ask the doctor to intervene and must impose a sanction if the injury is not visible or bleeding.

If a wrestler has a visible injury or is bleeding, the doctor will have the time necessary to treat the injury and will decide if the wrestler can carry on the match or not. There is no time limit.

In the case of any medical dispute, the doctor for the team of the wrestler in question has the right to intervene in any treatment required, or to give his advice on an intervention or decision made by the medical service. Only the FILA Medical Commission delegate may propose to the officials that the bout be stopped.

In competitions where there is no official doctor, the referee can suspend the bout for a maximum of two minutes in a match. The officials decide if the wrestlers are acting intentionally or not, and must apply the procedure mentioned in the above paragraphs.

This stoppage can be allowed on one or more times and is valid for both wrestlers.

The time-keeper for the mat concerned will announce each 30-second interval. The referee must invite the two wrestlers to return to the centre of the mat 10 seconds before the two minutes are up.



FEDERATION INTERNATIONALE DES LUTTES ASSOCIEES
INTERNATIONAL FEDERATION OF ASSOCIATED WRESTLING STYLES

Adresse : Rue du Château 6 / 1804 Corsier-sur-Vevey / Suisse
Téléphone : (41.21) 312 84 26 Fax : (41.21) 323 60 73 E-mail : fila@fila-wrestling.com Internet : www.fila-wrestling.com

In international competitions where the FILA Medical Commission is not represented, the decision to interrupt the bout will be taken by the FILA delegate or by the FILA nominated referee following consultation with the competition doctor and the injured wrestler's team doctor.

In all cases, the doctor making the decision to prohibit the wrestler from continuing the bout shall be of a nationality other than that of the wrestler in question, and the doctor must not be involved in the weight class concerned. (See health regulations.)

The wrestler who deliberately stops the bout without being injured or bleeding, automatically loses 1 point to his opponent.

All the first aid injuries (requiring no hospitalisation) occurring in FILA international competitions are at the organiser's costs. The injuries requiring hospitalisation are covered by the FILA licence, provided that the case has been announced to the insurance company (at the number appearing at the back of the card) the same day.

Article 58 – Doping

In applying the provisions of the FILA Constitution, and in order to combat the possibility of drug use, which is formally prohibited, FILA reserves the right to require that wrestlers undergo examinations or tests in all competitions it supervises. This provision must be applied at Continental and World Championships, according to FILA Regulations, and at the Olympic and Continental Games, according to IOC Rules.

In no case competitors or officers may oppose this verification without incurring immediate elimination and the penalties imposed for doping. The FILA Medical Commission will decide the time, the number or frequency of these examinations, which will be carried out by any means it deems useful. Suitable samples will be taken by a doctor certified by FILA, in the presence of an officer for the wrestler to be tested.

Whenever sampling is not carried out under the conditions set out above, the results obtained shall be considered void. (see Doping Regulations).

The setting up and financial implications of the anti-doping controls are paid for by the host country and the National Federations.

The FILA, being subject to the convention fighting drug use signed with the IOC and applied by the World Anti-Doping Agency (WADA), all its Regulations, procedures and sanctions are applicable by the FILA. The appeal body in the event of a doping sanction made by the FILA Bureau against a wrestler is the Court of Arbitration for Sport (CAS) in Lausanne (Switzerland).

CHAPTER 12 – APPLICATION OF THE WRESTLING RULES

These Rules supersede all former editions.

The FILA Executive Bureau is the sole decision-making authority concerning any modifications to the above provisions that are deemed desirable with a view to improving the technical Rules of wrestling.

These Rules have been drawn up bearing in mind all the circulars and information distributed by the FILA. They contain all the suggestions put forward by the auxiliary bodies and the Bureau which were accepted by the FILA Congress.



FEDERATION INTERNATIONALE DES LUTTES ASSOCIEES
INTERNATIONAL FEDERATION OF ASSOCIATED WRESTLING STYLES

Adresse : Rue du Château 6 / 1804 Corsier-sur-Vevey / Suisse **Téléphone :** (41.21) 312 84 26 **Fax :** (41.21) 323 60 73 **E-mail :** fila@fila-wrestling.com **Internet :** www.fila-wrestling.com

These Rules are the only valid document of their type until the following Congress which will be asked to rule on all the possible modifications or interpretations decided by the Executive Bureau.

In the event of a trial, only the French text is valid.

The National Federations must translate this document into their official language.

Every referee at a competition must have copy of these Rules in his language and in one of the FILA's official languages (French or English).